

# **BREAKERLESS** **STEALTH** **EDITION**<sup>™</sup>

## **ELECTRONIC IGNITION CONVERSION KIT**

1957-1974 General Motors V8 Single and Dual Point Distributors\* - Part No. 38131

*\*Legal for use on emission-controlled vehicles per CARB EO D-275-1*

### **PRODUCT DESCRIPTION**

This Breakerless-SE electronic ignition conversion kit is designed to convert GM V8 engines, originally **equipped with breaker points, windowed style distributor cap, screw-on rotor and stock coil**, to a solid-state electronic ignition. By utilizing a fully integrated trigger and power module, this entire conversion kit fits completely inside the distributor. Unlike competitive systems though, no additional wires protrude from the distributor, only the original points' wire. The result is a state-of-the-art ignition with an absolutely stock appearance.

#### ***Outstanding features of this unit include:***

- Single wire operation to preserve stock appearance and simplify wiring.
- Active dwell control maintains high rpm spark energy while reducing coil heating at idle.
- Auto-standby prevents coil damage or dead battery if the ignition is accidentally left on.
- Hall Effect rotary-vane sensor design compensates for worn bearings and distributor endplay. Sensor/Module is unaffected by oil, dirt or other contaminants, unlike optical systems.
- Over-voltage/over-current protected against damage from high amp battery chargers, reversed battery, or improper wiring.
- Constructed with premium quality components. Sealed, hi-temp thermoplastic housing provides exceptional resistance against moisture and vibration.
- No distributor modification, disassembly, or removal required.
- Easier starting. Reduced maintenance.
- 3-year limited warranty.

### **INSTALLATION**

#### **Parts included in this kit: (See Detail "A")**

Module (black) (1)	6-32 x 1/4" Brass Binding Head Screw (1)
Vane Section, with Attached Spacer (2)	8-32 x 1/4" Low Profile Hex Head Screw (1)
10-32 Small Pattern Hex Nut (2)	#8 Split Lock Washer (2)
#10 Split Lock Washer (2)	Flexible Wire Clamp (1)
10-32 x 1" Button Head Screw (2)	1/8" Hex Wrench (1)
8-32 x 3/4" Fillister Head Screw (2)	Small Blade Screwdriver (1)

#### **Tools required for installation:**

1/8" Hex Wrench (included)	7/32" Drill Bit, Small Round File or Ream
5/16" Socket or Box End Wrench	Medium Blade Screwdriver
Needle Nose Pliers	Small Blade Screwdriver (included)
Flat File or Grinding Stone	

## PLEASE READ THE ENTIRE INSTALLATION PROCEDURE BEFORE YOU BEGIN INSTALLATION!

Allow enough time to do the job right and you will be pleased with the results. This conversion kit may be installed with the distributor in the car. If you choose to remove the distributor, follow the procedure outlined in your vehicle's shop manual. Check the distributor for excessive side and endplay before you proceed with installation, and follow the procedure outlined for excessive side or endplay in your vehicle's shop manual.

1. Disconnect the battery negative (ground) cable from your battery.
2. Remove the distributor cap from the distributor, leaving the spark plug wires attached. Remove the rotor, condenser, and points. On dual point distributors, remove both point sets, condenser, and crossover wire. If the crossover is not a separate wire, cut at junction (see Detail "B").
3. Inspect the distributor. Twist the rotor mounting ears clockwise and release. The weights should move outward smoothly and snap back when released. Gently push the ears from side to side to check for bushing wear. Correct any problems now, as a malfunctioning distributor can rob the engine of several horsepower. Inspect the point wire for cracked or missing insulation. The point wire is the wire that runs from the distributor to the coil. If this wire is damaged, contact Lectric Limited for a replacement (available for most GM vehicles). Also verify that the point plate ground wire is in place and in good condition, without corrosion on the terminals or missing wire strands. The point plate ground wire grounds the point plate to the distributor housing. This wire may be located either above or below the point plate.
4. Before proceeding with the next step, thread the two 10-32 x 1" button head screws in and out of the rotor mounting ears one time to clean out the threads and remove any burrs from the screws. Next, mate the two vane sections together in your hands so they form a circle. Insert one of the 10-32 x 1" button head screws through the vane mounting ears on one side and place this assembly around the distributor shaft. Hold the screw with a pair of needle nose pliers next to the head and insert into the underside of the rotor mounting ear. Using the small screwdriver, turn the screw counterclockwise (looking from the top down) a couple of turns. Repeat with the other mounting ear (see Detail "C"). Pull the vane assembly up against the underside of the rotor mounting ears and run the screws the rest of the way up. Tighten firmly with the 1/8" hex wrench (not with the screwdriver!)
5. Install the 6-32 brass screw in the module. Slip the module through an opening in the vanes and slide it over to where the points were mounted. There is a small projection on the point plate that served as the point pivot. This must mate with the hole on the bottom of the module for proper seating.

**Dual Point Distributor Only:** Remove the breaker-plate mounting screw closest to where the point wire exits the distributor. Replace it with the supplied low-profile hex screw. The module will not seat properly with the original screw.

6. NOTE: It has been reported that with some rebuilt distributors, the bottom of the mechanical advance spring anchor post protrudes downward enough to touch the vane assembly (See arrow on Detail "F"). Upon tightening the 10-32x1" screws that secure the vane assembly, this post may make contact with the vane assembly causing the mechanical advance to bind. If this happens, you may choose to either press-in the post farther or (slightly) file-down the bottom of the post so that there is a small gap between the bottom of the post and the vane assembly (enough for a piece of paper to slide through).

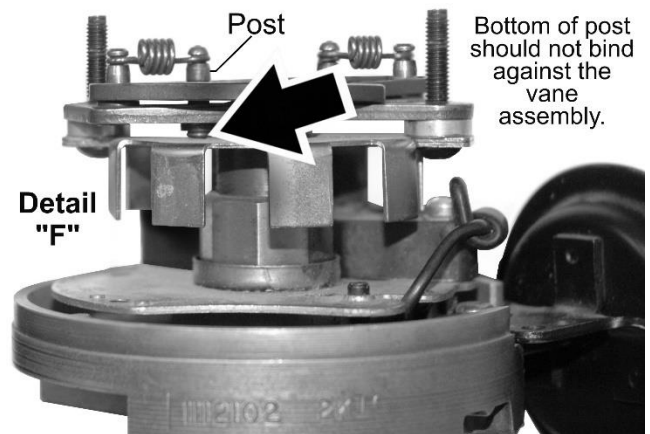

7. Fasten module with the 8-32 x 3/4" fillister head screws and #8 split lock washers. Place the flexible wire clamp between the module and lock washer on the side closest to where the point wire exits the distributor. The tab should point outward and will be used to keep the point wire away from the vanes (see Detail "D"). Tighten just until the washers are fully compressed. **DO NOT OVERTIGHTEN** or the threads in the point plate may become stripped.

8. **IMPORTANT:** Check that there is clearance between the vanes and the two halves of the sensor by twisting the advance mechanism. If you need to rotate the distributor body to get the vanes near the sensor slot, first put a locating mark on the distributor and engine block. This will allow the distributor to be easily reset to its original position.

9. Attach the point wire to the module. The terminal must be bent up at a 45° angle to prevent it from hitting the inside of the distributor cap when the vacuum advance mechanism moves the point plate. Loop the vinyl-coated tab around the wire and position it above the module, so it won't contact the vanes or distributor cap (see Detail "D").

10. The 2 mounting holes in the rotor usually need to be enlarged to allow the rotor to easily slide over the vane mounting screws. A 7/32" drill, small file, or plumber's ream can be used to open-up the holes slightly.

**IMPORTANT:** The square and round indexing pegs on the bottom of the rotor **must be shorter** than 1/8" for the rotor to seat properly. The 1/8" hex wrench can be used as a thickness gauge. Cut, grind, or file down as required (see Detail "E"). Improper seating may cause damage to the rotor. Install the rotor and fasten with the 10-32 nuts & #10 split lock washers.

Reinstall the distributor cap. Make sure all wires are firmly seated. Reconnect the battery ground cable.

## **WIRING**

For most installations the wiring is already completed. Replace any wiring that has cracked or missing insulation, corrosion, or questionable modifications. The distributor wire must be connected to coil (-). There may be additional wires connected for accessories such as a tachometer, alarm, shift light, etc. The +12V from the ignition switch that supplies power for the coil (with the key in run position) **MUST** pass through a resistance wire or ballast resistor (see below). There may be additional wires connected for a radio noise suppressor or resistance bypass wire (see below). However, **the coil (+) terminal should NEVER be used as a source of power for accessories such as tachometers, choke heaters, alarms, stereos, etc.**

## **IGNITION COIL**

The Breakerless-SE is optimized for use with the factory installed coil (ideally 1.3 ohms resistance across the primary winding of the coil). Aftermarket coils having a primary resistance of 1.2 to 1.8 ohms will also provide satisfactory performance. **WARNING! Do NOT use with a coil intended for capacitive discharge ignitions (CDI) or HEI systems as this will cause failure of the Breakerless-SE module, voiding your warranty! Do NOT use with any of the MSD Blaster, Flamethrower II/III, or similar type "hi-performance" coils. These coils can have a very low primary resistance (about 0.3-0.6 ohms) and will eventually destroy the Breakerless-SE module, voiding your warranty!**

**BALLAST RESISTOR or RESISTANCE WIRE (key in run position)** - This conversion kit is designed to work with, and **MUST** be used with, the factory installed ballast resistor or resistance wire. The ballast resistor (if applicable) usually takes the form of a small white ceramic block mounted on the firewall in series with the +12V from the ignition switch that supplies power for the coil. The opposite terminal of the ballast resistor then sends the proper voltage through a wire that directly connects to the coil (+) terminal. The resistance wire (if applicable) would have been integrated into the dash wiring harness or engine wiring harness. The purpose of the ballast resistor/resistance wire is to limit current, preventing coil overheating and premature burning of the ignition point. The resistance is typically in the range of 1.2 to 1.8 ohms. The ballast resistor or resistance wire should **NOT** be removed when installing the Breakerless-SE.

If the points have been wearing normally, then the ballast resistor/resistance wire is probably in place. If the points burn-up in about 300-500 miles (or less), then the ballast resistor/resistance wire may be missing or damaged. If the stock coil has been replaced with a low resistance (CDI or HEI) type, this would also cause the same effect. Correct any problems before operating the ignition.

**BALLAST RESISTOR or RESISTANCE WIRE BYPASS (key in the start/crank position)** – The draw of the starter motor will cause a modest to severe voltage drop in the electrical system. To assure the coil will develop sufficient spark voltage, the ballast resistor/resistance wire was factory-bypassed during cranking. This is **typically** accomplished by a wire in the factory installed engine harness that runs from the starter solenoid (R) terminal to the coil (+) terminal, or splices into the harness near the coil. The Breakerless-SE will usually function if the bypass is missing, however, to guarantee starting under all conditions, the bypass wire must be in place.

## **TIMING**

Disconnect the vacuum line from the distributor and plug the line. Start the engine and set the initial (or idle) timing according to your owner's manual (generally in the range of 5° to 10° BTDC at approximately 600 to 900 RPM).

If the crankshaft or distributor has been turned, the timing can be set statically. Place a mark on the distributor body below the cylinder #1 distributor cap tower. Turn the crankshaft to about 10° BTDC on the cylinder #1 COMPRESSION stroke. The rotor should be pointed near the mark. Rotate the distributor counterclockwise until the sensor is centered in the nearest vane opening. Now rotate the distributor clockwise just until the edge of the vane is in the middle of the sensor area. The timing will now be close enough to start the engine and set with a timing light.

# TROUBLESHOOTING



**WARNING!** The coil generates extremely high voltage, which can be lethal. For safety and convenience, use the test procedure outlined below, or as described in your shop manual. Do not perform this test if fuel vapors or any combustible materials are present.

## Engine won't start.

Was the car running before installation of this conversion kit? If not, first check fuel, compression, and wiring according to the procedures outlined in your vehicle's shop manual.

If the car started with the points but not after installation of this conversion kit, check that the rotor was re-installed and is properly indexed and the battery ground cable was re-attached. If the distributor was moved, the timing may be too far advanced or retarded. Set the timing statically as described in the previous section.

If this looks OK, use a test light to verify there is voltage present between the coil (+) terminal and ground, with the key in both the start and run positions. Loss of voltage may be due to blown fuse, faulty ballast resistor or improper wiring. With the key in the run position and the engine stopped, check that voltage is also present where the point wire connects to the module. This will verify continuity through the coil primary & the point wire.

Last, connect one lead of the test light to battery (+), and touch the other end to the point plate to verify continuity to ground. **Note!** Before beginning any tests, always first check that your test light works by connecting it across the battery.

If all this checks out, the coil or module may be suspect. To test the module (see image above), remove the point wire from the coil (-) and attach it to the test light. Connect the other end of the test light to +12 volts. The light should blink rapidly while the engine is being cranked and go out when the engine stops. If the light does not come on, or stays on when the engine is stopped, the module should be sent in for further testing. **Note!** This test must be performed with a test light; a voltmeter will not provide correct results.

If a bad coil is suspected, it should be replaced. We recommend that you use an original or original-type coil. You can also perform a live spark test. For this test, you will need to purchase a calibrated standard ignition test plug. These are manufactured by the K-D Tools Company (K-D part # 2757) and are available at most auto parts stores for under \$10. This plug forces the coil to generate a known voltage, providing an accurate pass/fail evaluation.

Turn **off** the ignition switch. Remove the high voltage wire from the coil. Remove one spark plug wire from the car and attach it to the test plug. Insert the other end into the coil. Clip the test plug to the hood hinge on the driver's side. Crank the engine over. The spark should easily jump the gap and will vary in color from blue (strong) to yellow (weak) depending on the output of the battery during cranking, as well as several other factors (you may need to do this test in a darkened area).

## Engine starts but runs rough.

Possible causes: a plug wire(s) was left off or swapped with another cylinder, timing is too far advanced or retarded, coil or plug wires are arcing to ground, broken plug wire, loose coil or module connection, low voltage, weak coil, coil polarity reversed.

If the distributor appears damaged or near the end of its useful life, it should be taken to a competent rebuilder to restore its original performance. A service provider is listed below:

T.I. Specialty -1631 Pheasant Run - Richmond, IN 47374 - (765) 962-4265

*(Note: TI Specialty is not associated with Lectric Limited. This company is only listed as a possible source for service.)*

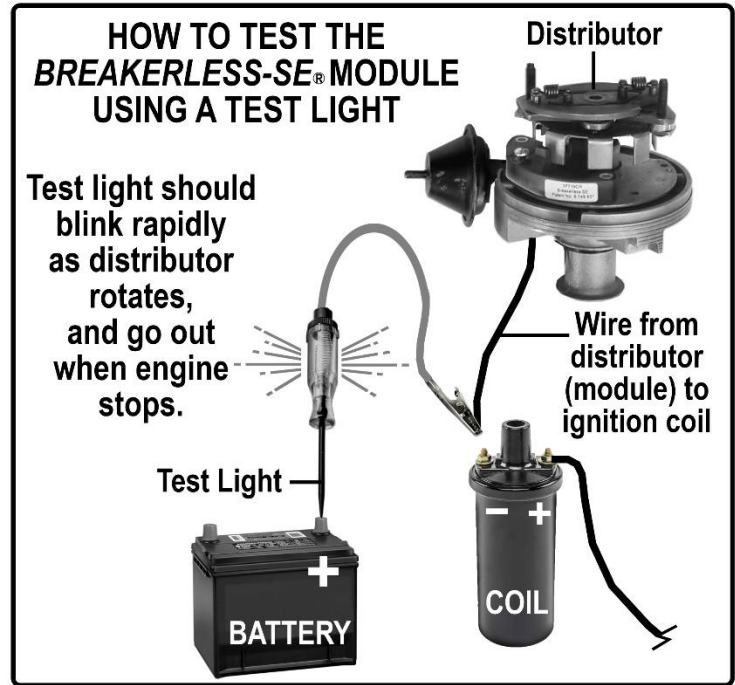

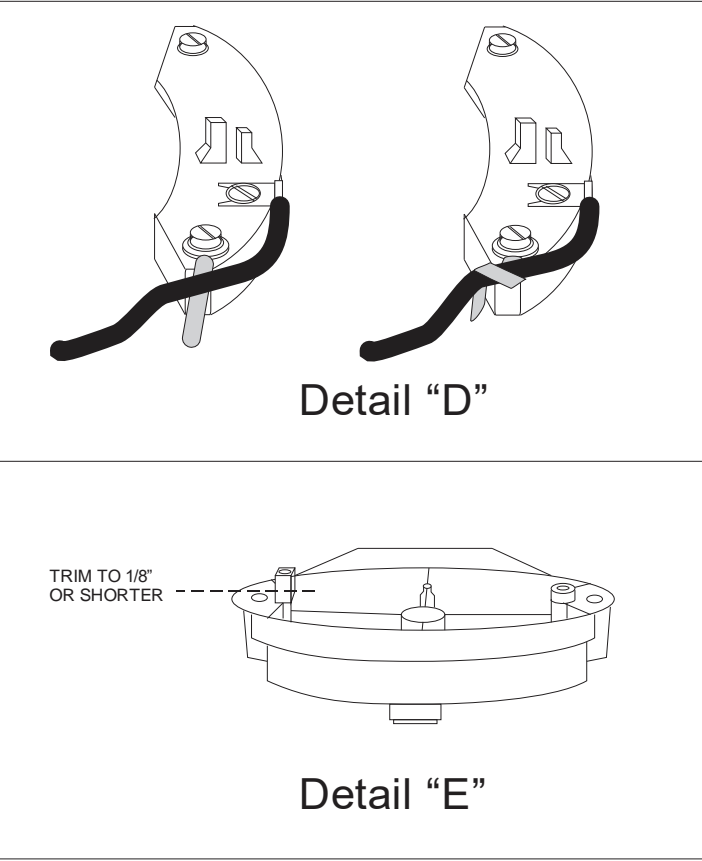
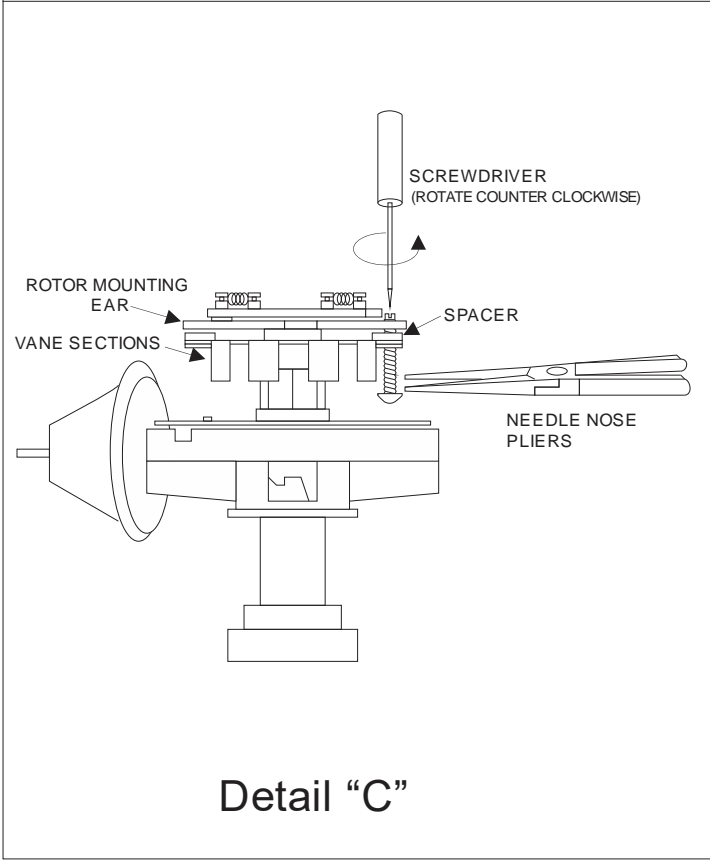
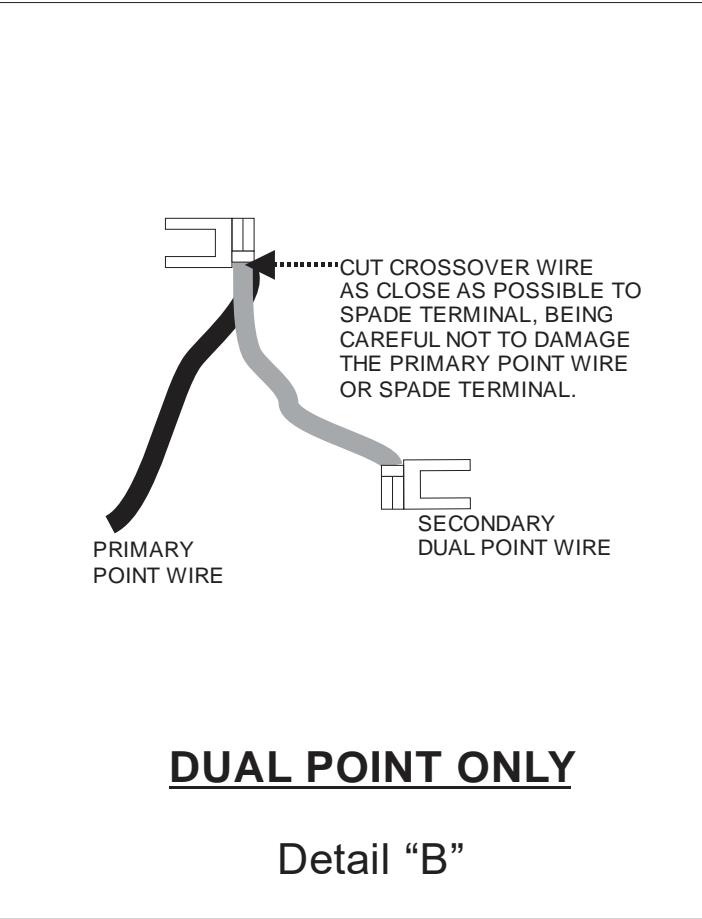
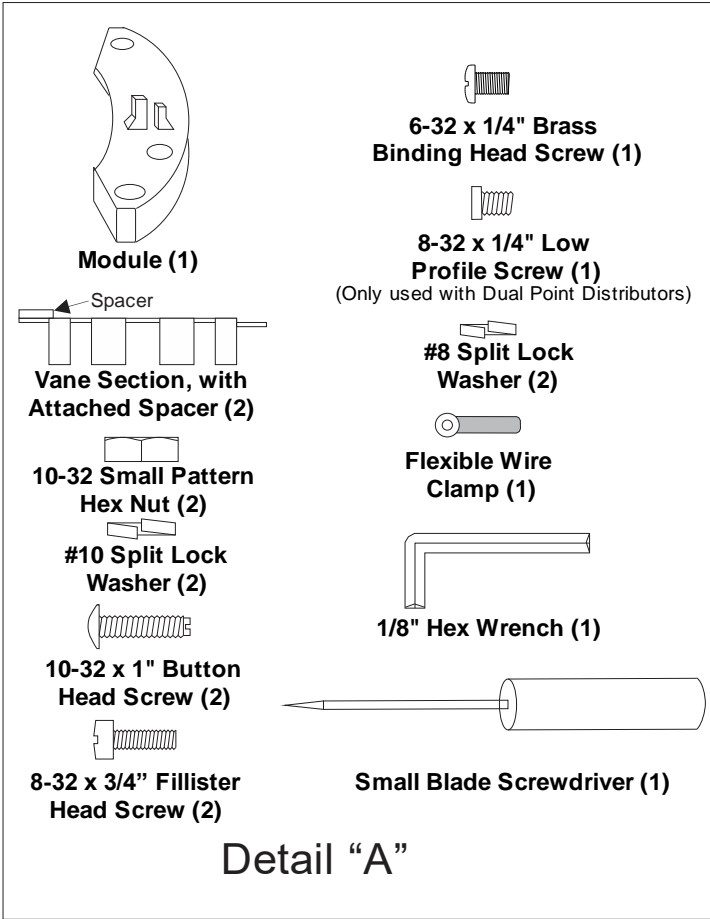



# HELPFUL INSTALLATION VIDEO

Go to link below or scan code

## <https://vimeo.com/871997910>



### THREE (3) YEAR LIMITED WARRANTY

Lectric Limited, Inc. warrants the enclosed ignition module to be free of defects in materials and workmanship for a period of three (3) years from the date of original purchase by the end user.

Lectric Limited, Inc. will repair or replace the enclosed module in the event of a manufacturing defect as follows:

**Parts:** Repair or replacement in exchange for defective module returned to our facility for three (3) years after the date of original purchase. Replacement warranty does not cover small hardware components (2 pc. vane assembly, nuts, screws, washers, etc.)

**Labor:** Repair or replacement of defective module returned to our facility for three (3) years after date of original purchase.

This warranty does not cover postage, freight, or delivery fees for sending the product to and from our facility. Warranty can be obtained during warranty period by shipping the product to:

**Lectric Limited, Inc.  
6750 W. 74<sup>th</sup> Street - Bedford Park, IL 60638**

Lectric Limited, Inc. warrants that for three (3) years from date of purchase, with proof of purchase, it will replace this product's module if found to be defective in materials or workmanship, when used as directed. If module becomes defective within the warranty period, call 708-563-0400 for an RMA (Return Merchandise Authorization) Number and return address. **Returns will not be accepted without an RMA number!** Then, return the module only (do not return the vane assembly and small hardware), postage prepaid with proof of purchase to Lectric Limited, Inc. for a prompt, no charge replacement. This replacement is Lectric Limited, Inc's sole obligation under this warranty. Lectric Limited, Inc. will not be responsible for any incidental or consequential damage which results from alteration, accident, misuse, abuse, neglect, installation or improper maintenance. The limit on liability may vary in your state and you may have additional rights and/or remedies depending on the state in which you live.

**WARNING!** The enclosed product is warranted to fit and operate properly in the specific application for which it is intended. Do not modify, alter, or tamper with this product without consulting Lectric Limited, Inc.

If the product is tampered with in any way, all warranties are void. If you experience any difficulties with the installation or the performance of any of our products, do not attempt any modifications without first contacting our technical support department at 708-563-0400.

Specifications, design, and instruction sheet subject to possible modification without notice, due to improvements.

For technical assistance call Lectric Limited, Inc. at  
708-563-0400  
M-F, 8:00 AM to 4:30 PM (Central Standard Time).



[www.LectricLimited.com](http://www.LectricLimited.com)